

M-660 PLine® Rotation Stage

Fast Positioning, Ultra-Low Profile



The M-660 PLine® rotation stage allows high positioning speeds of up to 2 full turns/sec. The 36 mm Ø clear aperture offers flexible usage

- **Unlimited Travel Range**
- **Max. Velocity 720 °/s**
- **Low Profile: Only 14 mm in Height**
- **Self-Locking Ceramic Direct Drive: Energy Saving & High Position Stability**
- **Direct Metrology Linear Encoder, up to 4 µrad Resolution**
- **PLine® Direct Drive: Non-Magnetic and Vacuum-Compatible Working Principle**
- **Compact Combinations with Linear Stages**

M-660 precision rotation stages use PLine® ultrasonic piezo

Application Examples

- Biotechnology
- Micromanipulation
- Microscopy
- Quality assurance testing
- Metrology
- Mass storage device testing
- R&D
- Photonics packaging

motors that act on a ceramic friction ring to drive the platform. This direct drive principle allows for the compact design and low profile of the stage. An integrated incremental encoder offers precision position control with up to 4 µrad resolution. The integrated U-164 PLine® linear motors provide a maximum torque of 0.3 Nm, independent from the direction of motion, and a maximum velocity of up to 720 °/sec. The maximum load is 2 kg.

M-660s can be built in different sizes or with other specifica-

tions, and they are available upon request as vacuum-compatible versions.

Advantages of PLine® Micropositioning Systems

Positioning systems equipped with ceramic ultrasonic drives of the PLine® series provide several advantages over positioners that apply classic drive technology:

- Smaller dimensions
- Higher holding force when powered down; no holding current
- Increased acceleration of up to 5 g
- Increased velocity of up to 500 mm/s or 720 °/s, resp.
- No leadscrews, gears or other mechanical components, no wear or maintenance
- No lubricants
- Non-magnetic and vacuum-compatible operating principle

Optimized Controller and Drive Electronics

For optimum performance, the highly specialized C-867 motion controller (s. p. 4-116) is recommended. This dedicated piezo motor controller also integrates the drive electronics which PLine® motors require to generate the ultrasonic oscillations on the piezoceramic element.

Furthermore, the controller has a number of special characteristics to address the requirements of ultrasonic motors, such as continuous automatic drive frequency adjustment, dynamic parameter switching for optimized high-speed motion and settling behavior. The broad-band encoder input (50 MHz) supports the outstanding high accelerations and

Ordering Information

M-660.55
PLine® Rotation Stage, Ø 108 mm, 360°, 34 µrad Resolution

M-660.45
PLine® Precision Rotation Stage, Ø 108 mm, 360°, 4 µrad Resolution

Ask about custom designs!

velocities of PLine® drives at high resolutions.

Patented Technology

The products described in this document are in part protected by the following patents:
US Pat. No. 6,765,335
German Patent No. 10154526

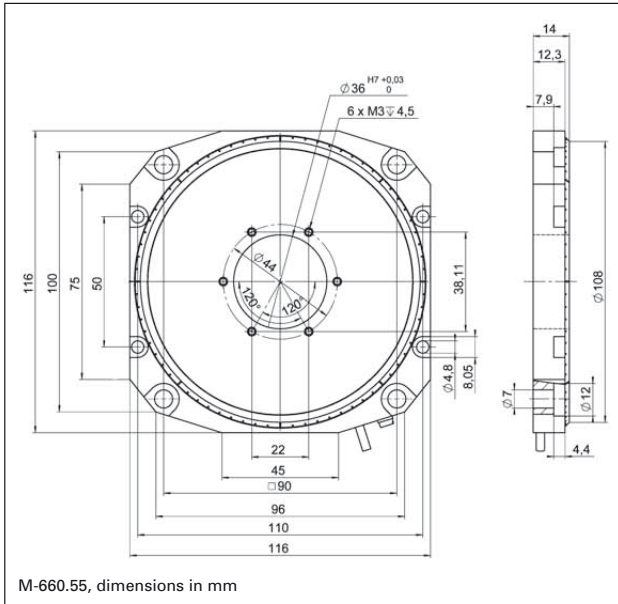

Technical Data

Model	M-660.55 / M-660.45	Units	Tolerance
Active axes	Theta Z		
Motion and positioning			
Rotation range	No limit	°	
Integrated sensor	Incremental encoder		
Design resolution	34 (0.00195) / 4 (0.00023)	μrad (°)	typ.
Min. incremental motion	34 / 12	μrad	typ.
Bidirectional repeatability	±68 / ±24	μrad	
Max. velocity	720	°/s	
Mechanical properties			
Load capacity/axial force	20	N	max.
Holding force	0.3	Nm	max.
Max. torque cw/ccw (θ Z)	0.3	Nm	max.
Drive properties			
Motor type	2 x U-164 PILine® ultrasonic piezo drive		
Operating voltage	60 (RMS)*	V	
Current consumption**	0.3 (2 max.)	A	
Reference switch	optical		
Miscellaneous			
Operating temperature range	-20 to +50	°C	
Material	Al (black anodized)		
Mass	470	g	±5%
Cable length	1.3	m	±10 mm
Connector	MDR, 14-pin		
Recommended controller/driver	C-867 single-axis controller/driver		

* The operating voltage is supplied by the drive electronics

** For drive electronics

Piezo • Nano • Positioning



news

Issue 40

Technical Progress with Ultrasonic Piezomotors



Leica Geosystems AG benefits from PILINE® ultrasonic motors employed in their newest generation of surveying instruments for geodesy. The requirements for the drive of the new "Leica TS30" total station were, amongst others, higher speeds, shorter positioning times and a very high positioning accuracy when moving the measuring optics.

These requirements were exceeded by far through the employment of PILINE® ultrasonic motors. PI's U-164 piezomotor was chosen for the vertical as well as the horizontal movement of the measuring optics. Rotations are produced by two such motors which are preloaded against a pivot mounted friction ring doubling as a brake when at rest. In operation, the ceramic piezomotors

oscillate with ultrasonic frequencies. Generating a feed motion of the friction ring. This principle of operation provides unrivalled speeds of >180 °/sec and high accelerations of up to 360 °/s² and an angular measuring accuracy of $0.5''$. The drive also improves starting and stopping behavior and reduces power consumption. The maintenance-free motors are self locking, i.e.

they generate high holding forces even when no electrical power is applied, they run extremely quiet and operate at ambient temperatures between -20 °C and $+50$ °C.

Continued on page 2

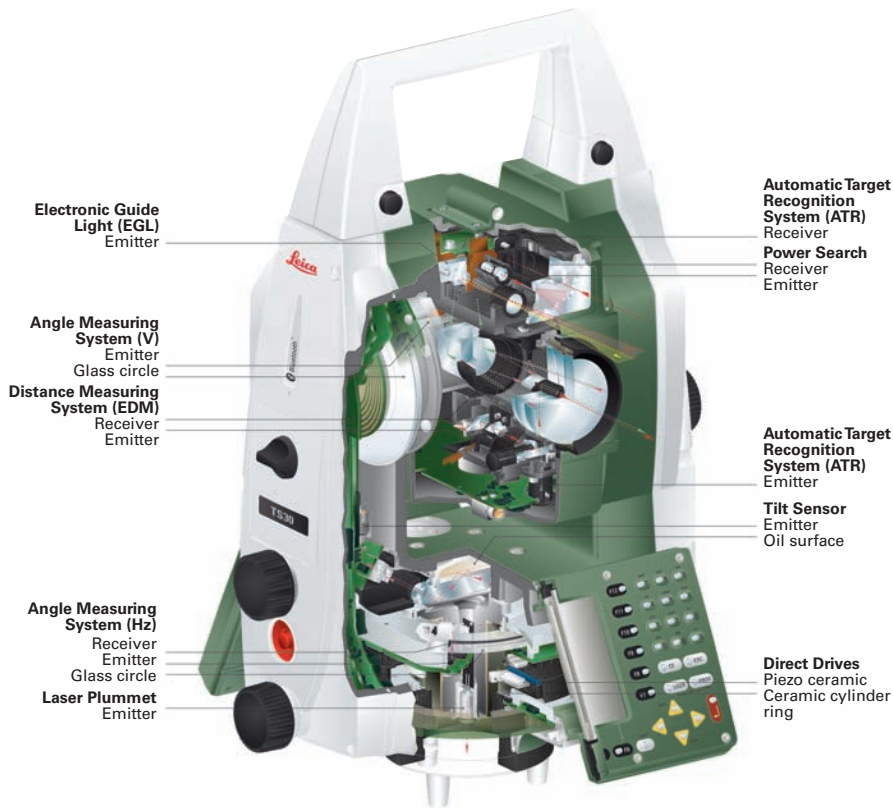

The cross-section of the total station shows the limited installation space available for the drives
 (Photo: Leica Geosystems AG, Switzerland)

As the above example illustrates, ultrasonic piezomotors continuously expand into new fields of application. Given their great flexibility,

it is hard to predict which application will benefit next from these novel drive systems.

Fast, Compact & Energy Efficient

OEM Ultrasonic Piezo Motors

U-164 ultrasonic piezo motors are particularly compact, reliable and maintenance-free drives which are self-locking when at rest and intrinsically non-magnetic and vacuum-compatible. In the application, they provide as yet unrivalled speeds and accelerations while offering a high positioning resolution and low power consumption.

With its PLine® series PI offers a broad range of positioning systems with piezo ultrasonic motors: From simple motors to fully integrated custom solutions.

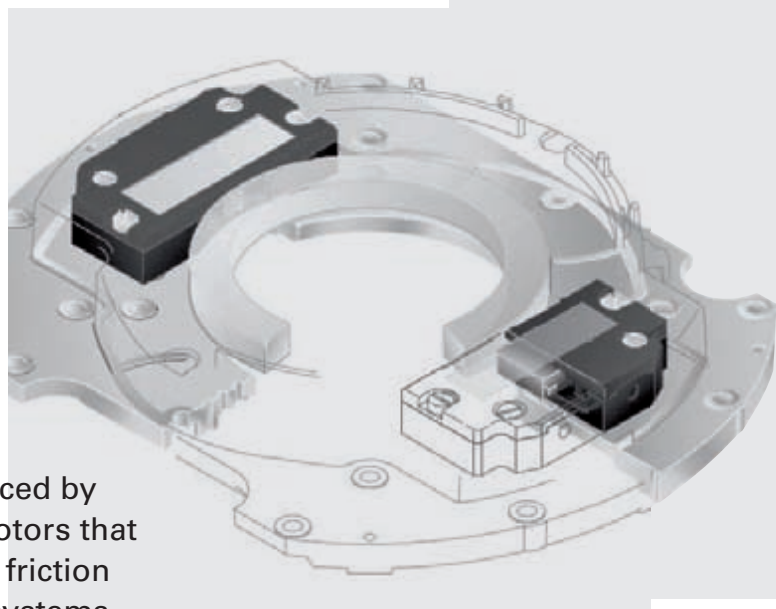

The rotations are produced by two U-164 ultrasonic motors that are preloaded against a friction ring. (Photo: Leica Geosystems AG/ Physik Instrumente (PI))

Piezoelectric Rotational Motor PMR 40.08

Linear Piezomotors: <http://www.piezo-motor.net>

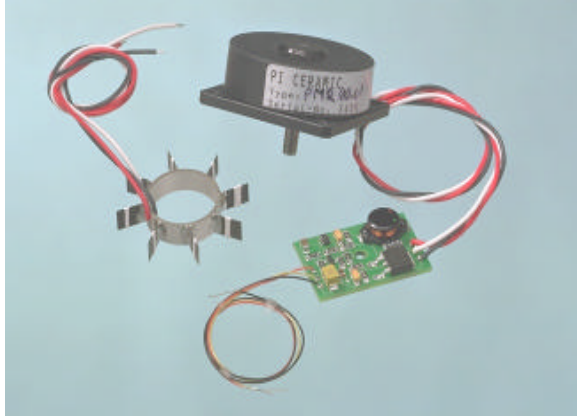

Fig. :1 Piezomotor PMR 40.08 and piezoresonator

PI Ceramic offers piezoelectric motors. They are classified as ultrasonic motors with ring-shaped resonator. The main components - with exception of the resonator - consist of special plastics, and they are manufactured by injection moulding processes. They are characterized by a simple construction, a low speed at a relatively high torque, small weight, and a small flat structural form.

For the operation of the motors various control devices have been developed for different power supplies. Figure 1 shows the motor type PMR 40.08 with control electronic and its piezoresonator.

Functional Principle

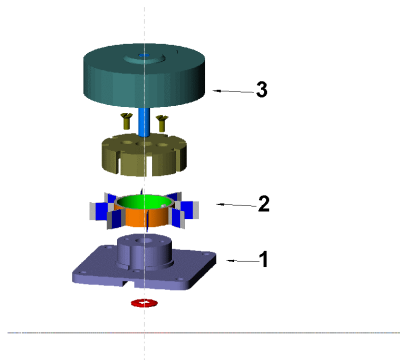

Fig.2: Explosive presentation of the piezomotor PM 40.08

As an active element the motors are based on a radially vibrating piezoresonator. The frequency depends on the diameter D of the piezoring and on the frequency constant N of the piezoceramic; its amount for the PMR 40.08 is approximately 52 kHz. On the edge of the cylinder of the resonator laminas of spring steel are mounted. These laminas are excited by the piezoresonator to lengthwise vibrations, and by the kind of arrangement to flexural vibrations. Both components of these movements superpose themselves in an elliptic motion. Part 1 is the baseplate, part 2 piezoresonator and part 3 the rotor.

Figure 3 demonstrates the modes of vibration of a lamina.

The elliptic movement of the tip of the lamina is divided into two ranges.

Range AB - expansion of the resonator: The free tip of the lamina is pressed to the friction surface of the rotor; by those means a kind of frictional tothing is originated between the tip of the lamina and the friction surface of the rotor. By this tothing the mechanical power is transferred to the rotor.

Range BA - contraction of the resonator
At range BA the free tip of the lamina loosens from the friction surface of the rotor, and so the rotor rotates without any losses due to friction.

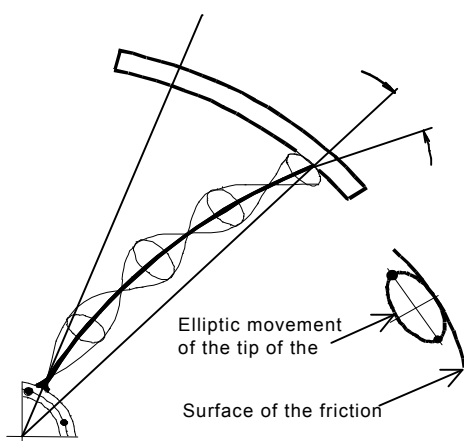
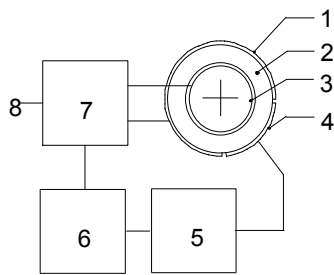

Fig.3: Vibration modes of a lamina

Electronic Motor Driving Unit



The control circuit operates as a self-excited generator. The resonant frequency of the piezoresonator determines the vibration frequency of the circuit, independent of working conditions, temperature and aging effects. Figure 4 shows the block diagram of the circuit. It consists of the piezoresonator 2 of the motor with the main electrodes 1;3. These ones are connected with the exit of the power amplifier. The auxiliary electrode 4 of the piezoresonator provides the actual value for the frequency control.

Fig.: 4 Block diagramm of the control circuit

Technical Parameters

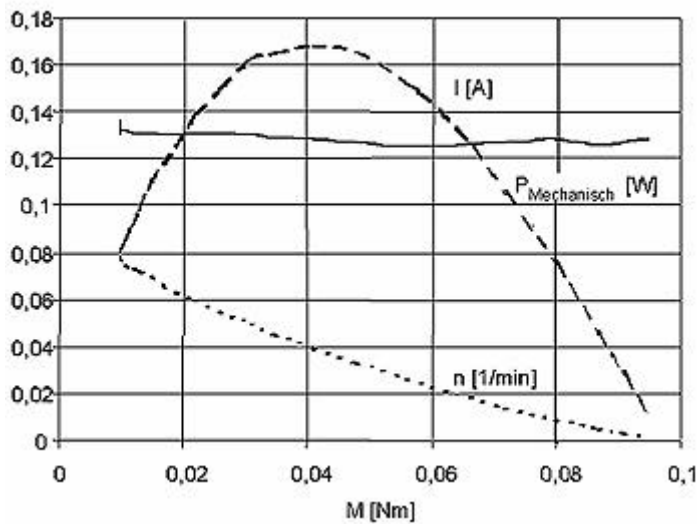

Fig.:5: Typical technical parameters of the Piezomotor PM 40.08

Figure 5 shows typical measured parameters in dependence on the torque M. All motors have gone in for a 12 hours' long-duration test, which causes the adaptation of the friction partners.

The diagrams of figure 5 have been measured with 12 V operating voltage. The input current of the control electronic is 130 mA, the maximal mechanical performance 170 mW at a torque of 0,04 Nm and the maximal rotational speed is 80 rpm at a torque of 0,01 Nm.

Directions for Application

Depending on the principle lamina-motors have only one direction of rotation. They are well suited at all situations, where the use of customary DC-motors with a gear is problematic, for instance by causing a slow, unidirectional rotational motion (size, structural form, weight).

The motors do not show *emit* a stray magnetic field, and optionally they can be manufactured of non-magnetic materials, allowing an operation within high magnetic fields. The electric radiation of the motors can be screened off easily.

The motors are not inflammable, they do not produce sparks, and they are suited for surroundings with a high explosion hazard. The rotational speed of the motors can be reduced, similar to a DC-motor, by decreasing the working stress. The motor operates similar to a stepping motor by pulse-width modulation technique of the control voltage. The motors have an excellent start-stop performance with reaction times in a range of milliseconds and possible cycle times of some 100 Hz.

P-653K PLine® Miniature Rotary Piezo Motor & Linear Actuators

Compact PCB Mounted Motion Control Solutions for OEMs



Two custom piezo motors based on the P-653 ultrasonic miniature motor show the versatility and adaptability of the basic concept: P-653KMRD on the right is based on the RodDrive principle and provides a virtually unlimited linear travel range. With the P-653KROT three miniature motors move a ring, for example for fast positioning of optical elements

- **Cost-Effective OEM Drive for High Quantity-Applications**
- **Preassembled and Mounted on a PCB Board**
- **Miniature Piezo Motor Drive: 8 mm Length Only!**
- **Fast Response: Full Stroke in <50 ms for Single Actuators**
- **Force Generation to 0.15 N; Torque to 2 mNm**
- **Self Locking at Rest**
- **Travel Range 50 mm (Runner), Velocity up to 200 mm/s and 230 rev/min, respectively**

Technical Data

Model	P-653KMRD	P-653KROT
Active axes	X	θ_z
Motion and positioning		
Travel range	50 mm	>360 deg
Step size at 0.25 ms ON time	5 to 15 μm	0.2 to 0.5 arcsec
Step size at 1.0 ms ON time	20 to 120 μm	0.6 to 3.5 arcsec
Max. velocity, without load	100 to 200 mm/s*	200 to 230 rev/min
Typ. velocity, without load	50 to 90 mm/s	120 to 150 rev/min
Mechanical properties		
Holding force when powered down	0.3 N	-
Max. push / pull force	0.15 N	-
Max. torque active / passive	-	2 / 4 mNm
Drive properties		
Resonant frequency (typ.)	515 kHz	515 kHz
Integrated piezo motor	P-653 PLine®	3 x P-653 PLine®
Operating voltage driver electronics	5 VDC	5 VDC
Current consumption incl. drive electronics	0.1 A	0.3 A
Control voltage	5 V TTL	5 V TTL
Miscellaneous		
Operating temperature range	-40 to +80 °C	-40 to +80 °C
Mass	2 g $\pm 5\%$	4.5 g $\pm 5\%$
Connectors	Miniature 4 pin connector	Miniature 4 pin connector
Recommended driver	Piezomotor drive electronics included	Piezomotor drive electronics included
Dimensions	40 x 10 x 4 mm incl. drive electronics	\varnothing 40 mm, 5 mm high incl. drive electronics, clear aperture \varnothing 14 mm
Typ. min. endurance	25 km	1.000.000 cycles

All data refer to 100% duty cycle.

*no load. Differing data at 5g: 80 to 140 mm/s, at 10g: 50 to 100 mm/s

Application Examples

- Consumer electronics
- Miniature mechatronics
- Micromanipulation
- Micropositioning
- Medical technology
- Optomechanics: Rotating Filters, etc.



The P-653 miniature drive including the drive electronics measures only 11 mm

For more information click here or to www.pi.ws